

Transformateurs de courant / Stromwandler

BD



CLIQUEZ SUR LES IMAGES
pour accéder aux fiches techniques
AUF DIE BILDER KLICKEN
um zu den Datenblättern zu gelangen

JK

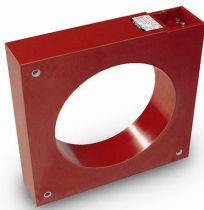

JK-S



Ouvrable / Teilbar

JKS-G
Outdoor

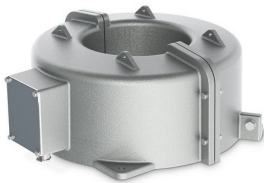

Ouvrable / Teilbar

Pour extérieur / Aussenanwendung

Transformateurs de tension / Spannungswandler

VD
1-pôle
1-Polig



WD
2-pôles
2-Polig



Medium voltage instrument transf. Block design

Indoor

VD (12 -72) kV

WD (12 -36) kV

BD (12 -72) kV



Current and voltage – our passion





Voltage transformer VD (12–72) kV

Medium voltage transformers of the type VD are used in indoor switchgear. They transform high voltages into standardised, equivalent values for counters, measuring equipment and protection devices.

The 1-pole isolated voltage transformer in a dry block design has been developed for use in air-insulated medium voltage cells.

A specific core padding and the complete casting of all active parts in epoxy resin ensures that the magnetic properties, and therefore the class accuracy, remain constant for decades.

Safe operation is guaranteed thanks to compliance with the partial discharge limit values of IEC 61869-1.

Any installation position is normally possible.

However, when using the 72 kV variant, the installation position must be discussed with the manufacturer in order to take account of any mechanical requirements (earthquakes, vibrations), unless the device is installed upright.

The voltage transformers are designed according to the applicable national and international standards. It is normally possible to accommodate special customer requirements upon request.



Advantages of the VD

- Indoor use
- Constant class accuracy
- Two different transformation ratios available
- Suitable for use in medium voltage cells



Voltage transformer VD (12–72) kV

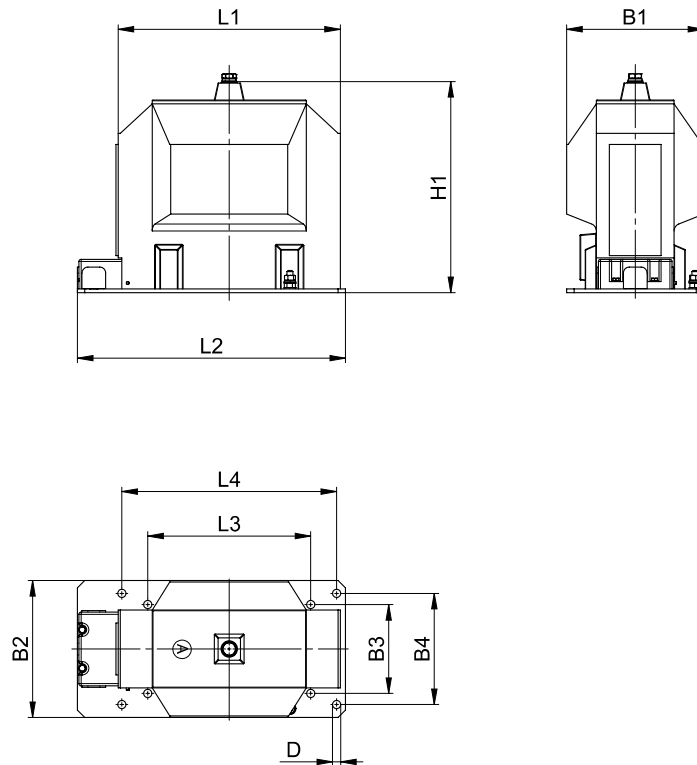

* Schematic dimension drawing

Type VD		12-M1	24-M1	36-O1	72-T1
Standard		DIN / IEC / IEEE			
Maximum system voltage	kV	12	24	36	72.5
Power frequency withstand voltage	kV	28	50	70	140
Lightning impulse withstand voltage	kV	75	125	170	325
Frequency	Hz	50/60			
Accuracy classes		0.1 – 3; 3P; 6P			
Thermal limit	VA	450	450	600	1500
Max. total power (cl. 0.2)	VA	25	25	40	40
Max. total power (cl. 0.5)	VA	75	75	100	100
Insulating material class		E			
Max. number of windings		2	3	3	3

Type VD		12-M1	24-M1	36-O1	72-T1
L1 length of voltage transformer	mm	300	300	375	410
L2 length of voltage transformer including	mm	362	362	432	475
L3 / L4 length of hole spacing in base plate	mm	220 / 290	220 / 290	290 / 350	300
H1 height of voltage transformer including	mm	285	285	350	770
B1 width of voltage transformer	mm	185	185	222	285
B2 width of base plate	mm	150	150	225	285
B3 / B4 width of hole spacing in base plate	mm	120 / 150	120 / 150	150 / 200	200
D diameter of fastening hole	mm	11	11	11	14
Weight approx.*	kg	27	27	44	102





Voltage transformer WD (12–36) kV

2-pole isolated medium voltage transformers of the type WD are used in indoor switchgear. They transform high voltages into standardised, equivalent values for counters, measuring equipment and protection devices.

The 2-pole isolated voltage transformer in a dry block design has been developed for use in air-insulated medium voltage cells.

A specific core padding and the complete casting of all active parts in epoxy resin ensures that the magnetic properties, and therefore the class accuracy, remain constant for decades.

Safe operation is guaranteed thanks to compliance with the partial discharge limit values of IEC 61869-1.

Any installation position is possible.

The voltage transformers are designed according to the applicable national and international standards. It is normally possible to accommodate special customer requirements upon request.



Advantages of the WD

- Indoor use
- Constant class accuracy
- Two different transformation ratios available
- Suitable for use in medium voltage cells
- The 2-pole design of the voltage transformer in conjunction with the Aron circuit makes it possible to measure energy levels with just two voltage transformers and two current transformers



Voltage transformer WD (12–36) kV

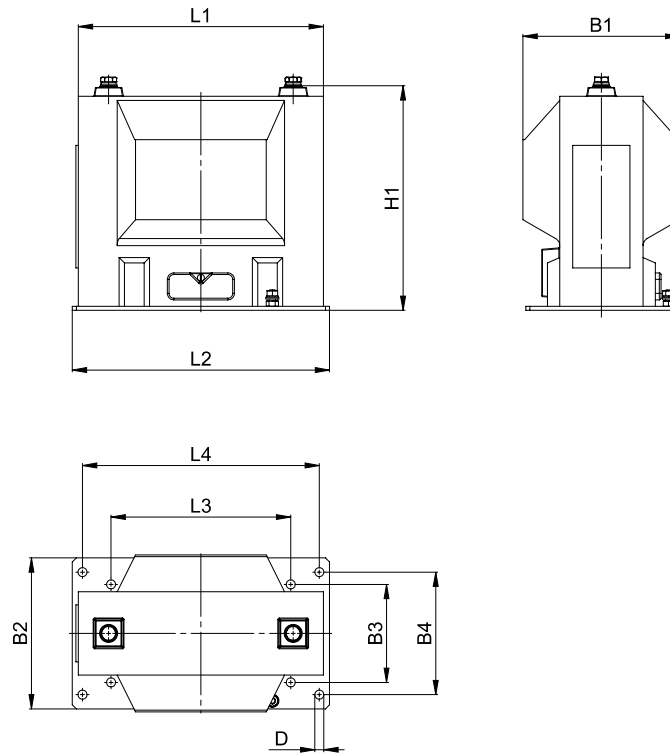

* Schematic dimension drawing

Type WD		12-M1	24-M1	36-O1
Standard		DIN / IEC / IEEE		
Maximum system voltage	kV	12	24	36
Power frequency withstand voltage	kV	28	50	70
Lightning impulse withstand voltage	kV	75	125	170
Frequency	Hz	50 / 60		
Accuracy classes		0.1 – 3; 3P; 6P		
Thermal limit	VA	600	750	750
Max. total power (cl. 0.2)	VA	40	40	75
Max. total power (cl. 0.5)	VA	125	125	200
Insulating material class		E		
Max. number of windings		1	1	3

Type WD		12-M1	24-M1	36-O1
L1 length of voltage transformer	mm	300	300	375
L2 length of voltage transformer including	mm	315	315	380
L3 / L4 length of hole spacing in base plate	mm	220 / 290	220 / 290	290 / 350
H1 height of voltage transformer including	mm	275	275	415
B1 width of voltage transformer	mm	185	185	222
B2 width of base plate	mm	185	185	225
B3 / B4 width of hole spacing in base plate	mm	120 / 150	120 / 150	150 / 200
D diameter of fastening hole	mm	11	11	11
Weight approx.*	kg	28	28	45



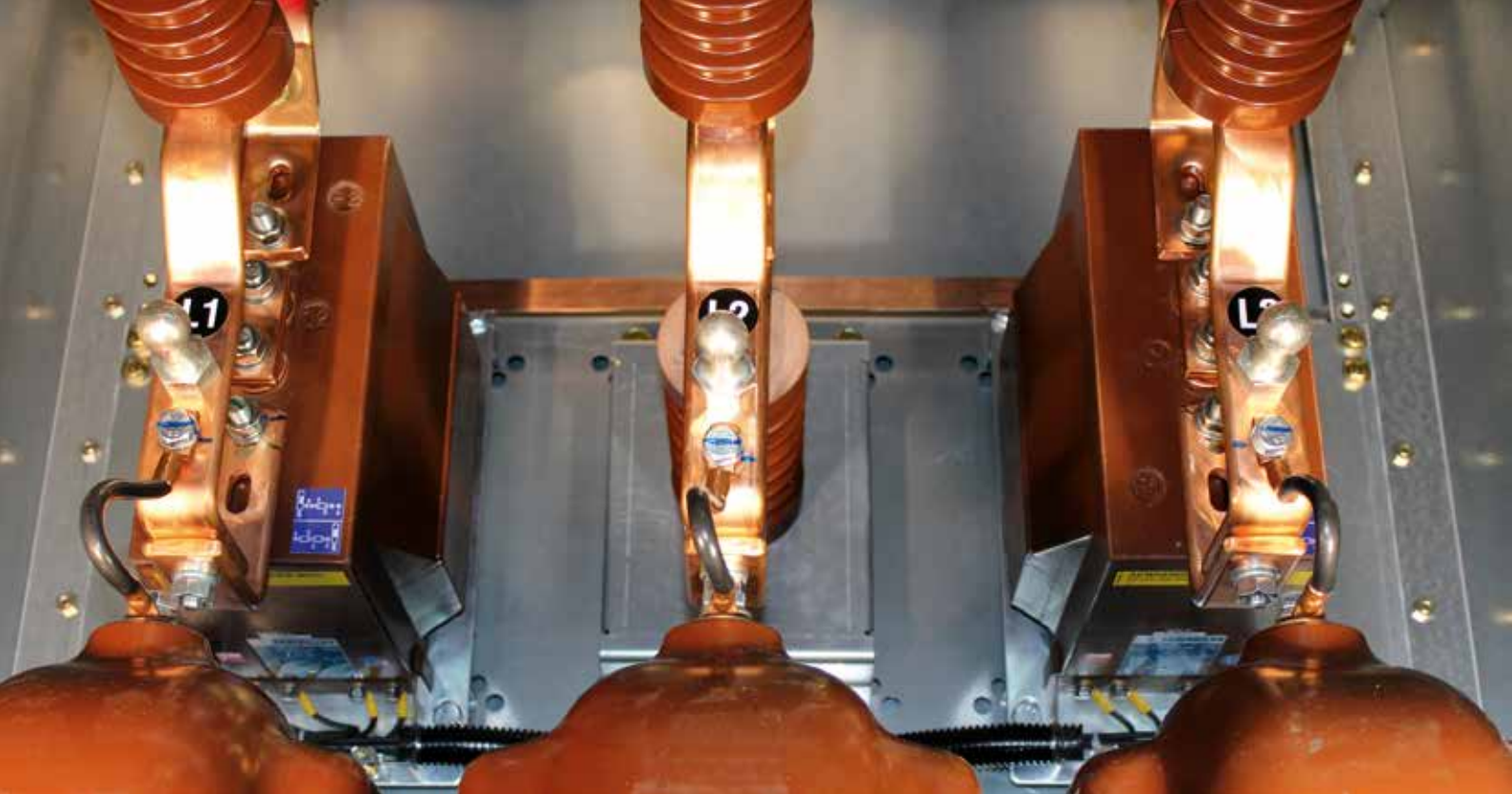

Current transformer BD (12–72) kV

Medium voltage current transformers of the type BD are used in indoor switchgear. They transform high currents up to 2500 A into standardised, equivalent values for counters, measuring equipment and protection devices.

The support-type current transformer in a dry block design has been developed for use in air-insulated medium voltage cells.

A specific core padding and the complete casting of all active parts in epoxy resin ensures that the magnetic properties, and therefore the class accuracy, remain constant for decades.

Safe operation is guaranteed thanks to compliance with the partial discharge limit values of IEC 61869-1.

The primary and secondary connections are made of brass as standard, while the protective cover on the secondary terminals is constructed from transparent polycarbonate. Any installation position is normally possi-

ble. However, when using the 72 kV variant, the installation position must be discussed with the manufacturer in order to take account of any mechanical requirements (earthquakes, vibrations), unless the device is installed upright.

The current transformers are designed according to the applicable national and international standards. It is normally possible to accommodate special customer requirements upon request.



Advantages of the BD

- Indoor use
- Constant class accuracy
- up to 2500 A
- Primary switching function
- High class accuracy even at small primary nominal currents thanks to primary windings
- Suitable for use in medium voltage cells



Current transformer BD (12–72) kV

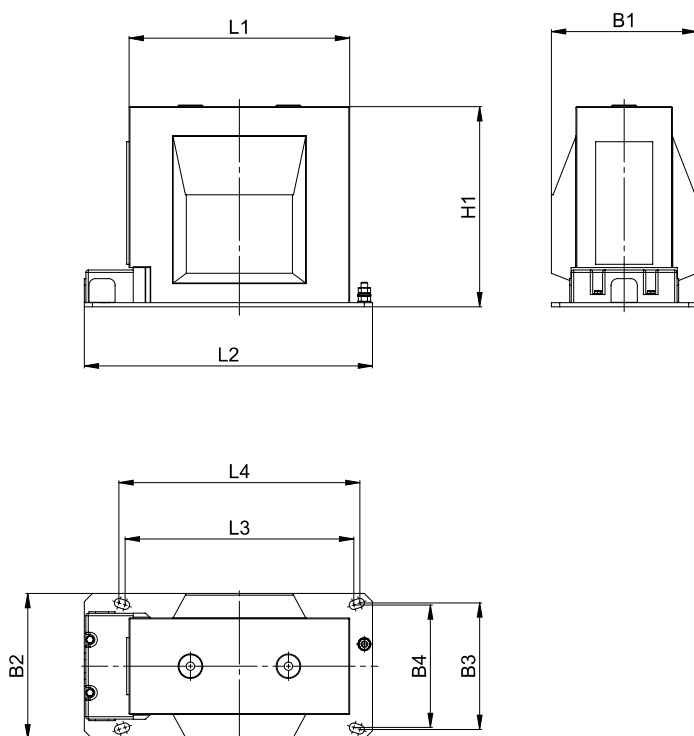

* Schematic dimension drawing

Type BD		12-G1	24-G1	36-G1	72-L1
Standard		DIN / IEC / IEEE			
Maximum system voltage	kV	12	24	36	72.5
Power frequency withstand voltage	kV	28	50	70	140
Lightning impulse withstand voltage	kV	75	125	170	325
Frequency	Hz	50 / 60			
Primary nominal current	A	10 – 2000			10 – 2500
Primary switching up to	A	2 x 600			2 x 1000
Secondary nominal current	A	1 / 5			
Accuracy classes		0.1 – 3; 3P; 6P			
Thermal limiting current [I _{th}]	kA/1s	≤ 50			
Insulating material class		E			
Max. number of cores		3			

Type BD		12-G1	24-G1	36-G1	72-L1
L1 length of current transformer	mm	270	270	270	355
L2 length of current transformer including	mm	353	295	353	417.5
L3 / L4 / L5 length of hole spacing in base	mm	280 / 295	280 / 295	280 / 295	300
H1 height of current transformer including	mm	245	245	355	650
B1 width of current transformer	mm	178	178	210	310
B2 width of base plate	mm	178	178	178	310
B3 / B4 width of hole spacing in current	mm	150 / 155	150 / 155	150 / 155	225
Weight approx.*	kg	27	27	36	105



Global presence

PIFFNER Instrument Transformers Ltd
5042 Hirschthal
Switzerland

☎ +41 (0)62 7392828
✉ sales@pmw.ch
💻 www.pfiffner-group.com/pch

PIFFNER Systems Ltd
4303 Kaiseraugst
Switzerland

☎ +41 (0)61 4676111
✉ info@pfiffner-systems.com
💻 www.pfiffner-systems.com

PIFFNER Deutschland GmbH
25524 Itzehoe
Germany

☎ +49 (0)48 21408270
✉ sales@pfiffner-messwandler.de
💻 www.pfiffner-group.com/pde

PIFFNER Transformatör A.S.
06750 Akyurt/Ankara
Turkey

☎ +90 (0)31 28475521
✉ info@pfiffner.com.tr
💻 www.pfiffner-group.com/ptr

PIFFNER do Brasil Ltda
88307-740 Itajaí
Brazil

☎ +55 (0)47 33481700
✉ pfiffner@pfiffner.com.br
💻 www.pfiffner-group.com/pbr

PIFFNER Instr. Transf. private Ltd
178/2 Village Sarul, Nashik
India

☎ +91 62 9823010690
✉ info@pfiffner.in
💻 www.pfiffner-group.com/in

MGC Moser-Glaser Ltd
4303 Kaiseraugst
Switzerland

☎ +41 (0)61 4676111
✉ info@mgc.ch
💻 www.mgc.ch

ALPHA Elektrotechnik Ltd
2560 Nidau
Switzerland

☎ +41 (0)32 3328700
✉ mail@alpha-et.ch
💻 www.alpha-et.ch

HAEFELY Ltd
4052 Basel
Switzerland

☎ +41 (0)61 373 41 11
✉ sales@haefely.com
💻 www.haefely.com

This document has been drawn up with the utmost care. We cannot, however, guarantee that it is entirely complete, correct or up-to-date.

©Copyright PFIFFNER, subject to change without notice 2020.08



PFIFFNER

Current and voltage – our passion

HV

HIGH VOLTAGE

MV

MEDIUM VOLTAGE

LV

LOW VOLTAGE



Cable current transformers

Indoor and outdoor operation

JK
JKS / JKS-S
JK-G / JKS-G
JKF
JLD

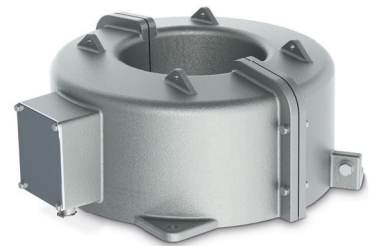
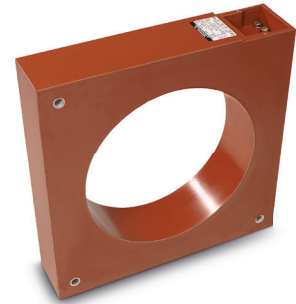

PFIFFNER

Current and voltage – our passion



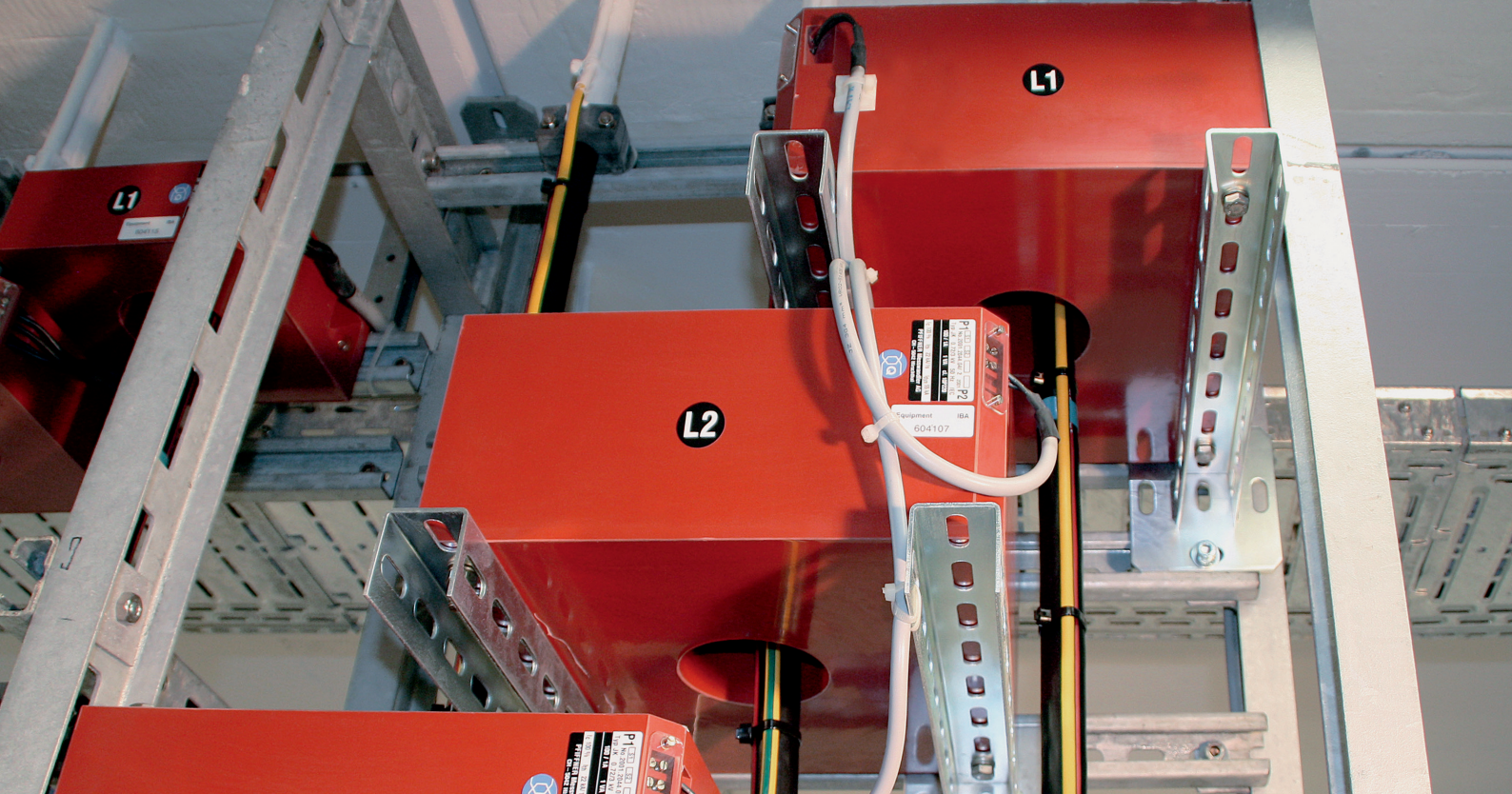

Current transformers JK

Cable current transformers type JK are used in indoor switchgears. They transform high currents up to 5000 A into standardised values for meters, measuring and protection devices.

The cable current transformer is designed for installation on fully insulated medium and high voltage cables or for installation on medium and high voltage bushings. This enables a space-saving system design. Primary currents of up to 5000 A can be measured.

A specific core padding and the complete casting of all active parts in polyurethane (PUR) ensures that the magnetic properties, and therefore the class accuracy, remain constant for decades.

The standard secondary terminal enclosure permits a housing degree of protection up to IP 20. Optionally, secondary terminals can be integrated in a terminal box, providing a housing degree of protection of up to IP 65. Thanks to a wide range of geometric dimensions the cable current transformer can be adapted to customer requirements. Applicable installation options are also available in various designs, as well as any type of installation position.

The transformers are designed according to applicable national and international standards. Designs that meet customer-specific standards are possible on request.

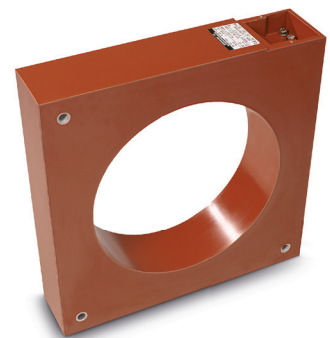

Advantages JK

- Constant class accuracy
- Rated primary currents up to 5000 A
- Suitable for installation over fully insulated HV and MV cables
- Suitable for indoor applications with degree of protection IP 20 or IP 65
- Wide range of geometric dimensions
- Any installation position



Current transformers JK

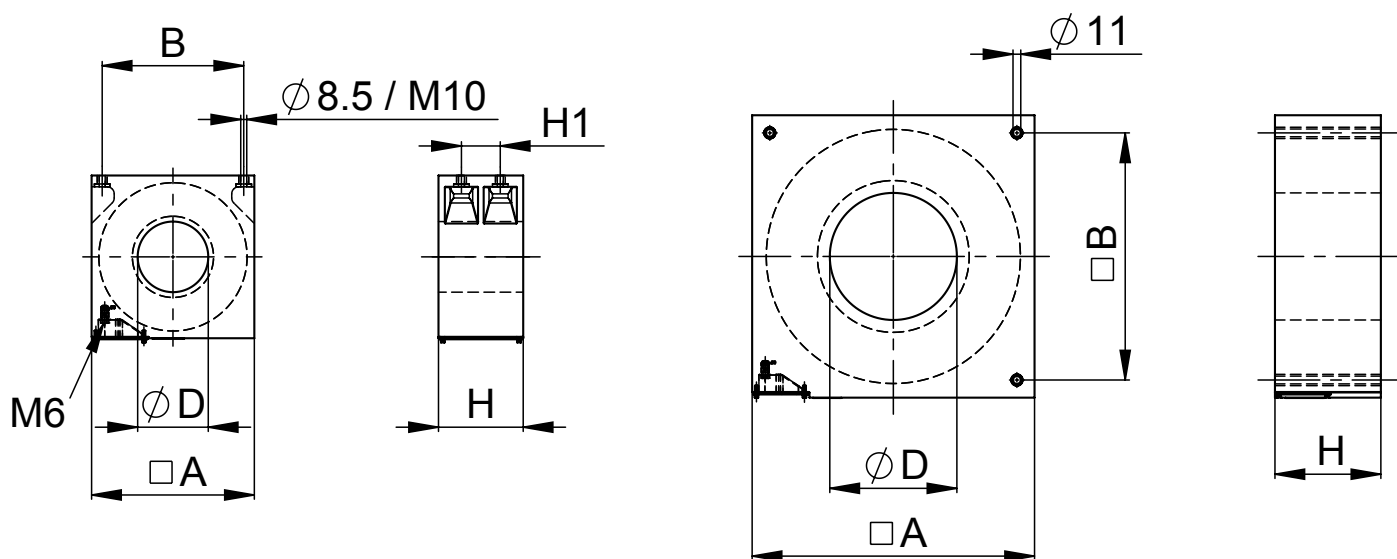

Type JK		DIN/IEC/IEEE
Standard		DIN/IEC/IEEE
Highest voltage for equipment	kV	0.72
Rated power-frequency withstand voltage	kV	3
Frequency	Hz	16.7/50/60
Primary rated current	A	1–5000
Secondary rated current	A	1/5
Rated short-time thermal current [I _{th}]	kA/1s	100 x I _n
Rated dynamic current [I _{dyn}]	kA	2.5 x I _{th}
Accuracy class		0.1–3; 0.2S; 0.5S; P; PR; PX; PXR; TPX; TPY; TPZ
Max. number of cores		4

Type JK		A	mm	230	350	400	450
Transformer size	A	mm		230	350	400	450
Height of unit	H	mm		80–180	80–300	100–300	100–300
Internal diameter	D	mm		50–180	60–250	100–290	100–290
Distance between screw holes at base	B	mm		200	300	350	400



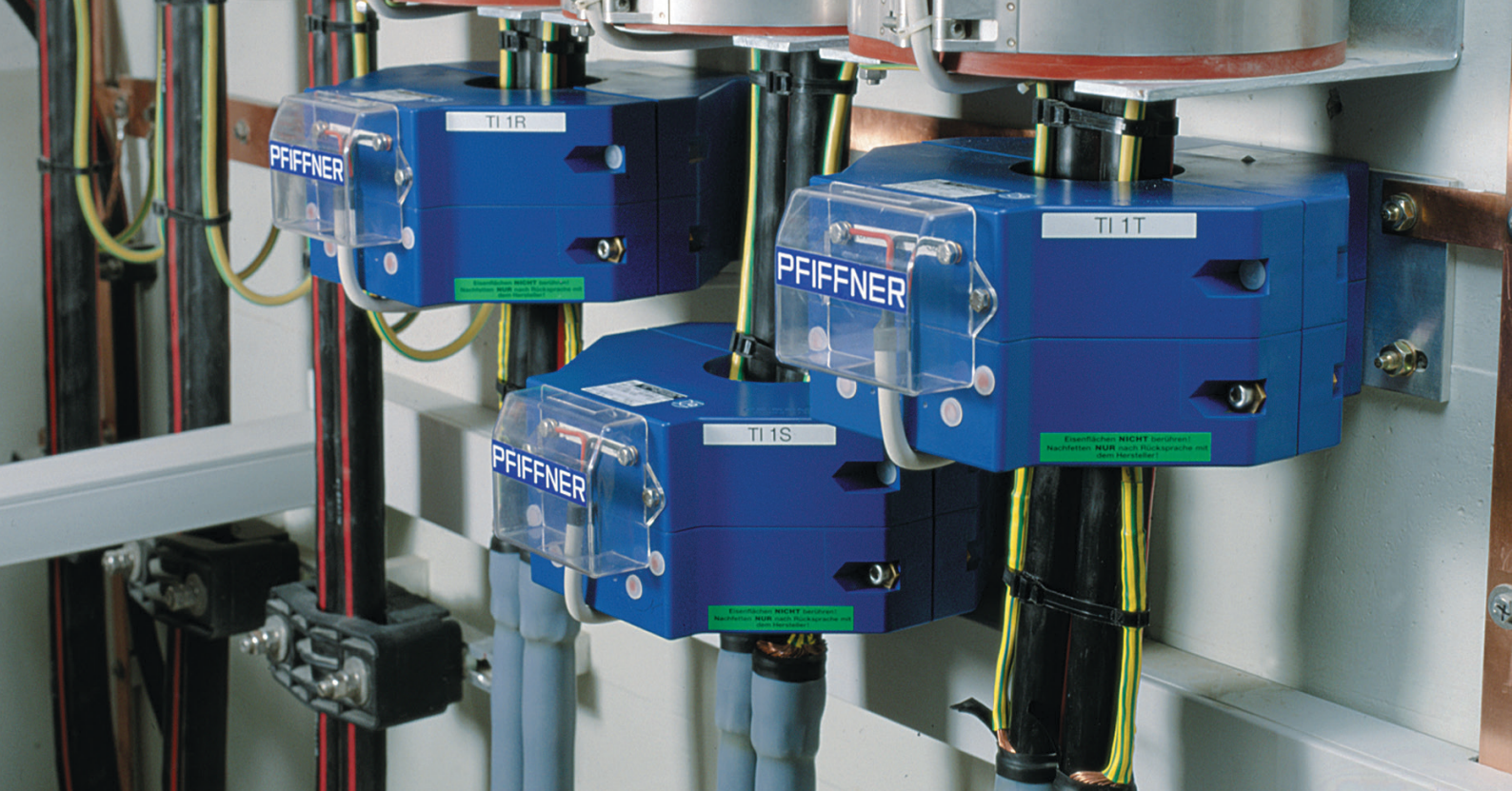

Current transformers JKS / JKS-S

Split core cable current transformers of type JKS/JKS-S are used in indoor switchgears. They transform high currents up to 3000A into standardised values for meters, measuring and protection devices.

The split core cable current transformer is designed for subsequent installation on fully insulated medium and high voltage cables. This enables retrofitting of existing systems in a simple manner. Primary currents of up to 3000A can be measured.

A specific core padding ensures that the magnetic properties, and therefore the class accuracy, remain constant for decades. The active part is cast in polyurethane (PUR). Type JKS transformers come with a housing degree of protection up to IP 20; type JKS-S transformers up to IP 40. Thanks to a wide range of geometric dimensions the cable current transformer can be adapted to customer requirements. Any installation position is normally possible.

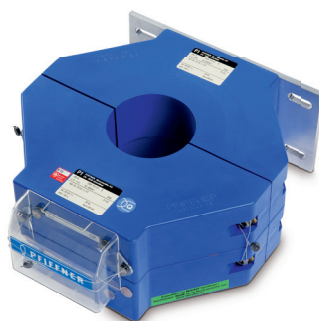

Advantages JKS-S

- Suitable for subsequent installation over fully insulated HV and MV cables
- Suitable for indoor applications with degree of protection IP 20, on request IP 40
- Wide range of geometric dimensions
- Secondary terminals for cables up to max. diameter of 6mm²



Advantages JKS

- Suitable for subsequent installation over fully insulated HV and MV cables
- Suitable for indoor applications with degree of protection IP 20, on request IP 40
- Wide range of geometric dimensions
- Secondary terminals for cables up to max. diameter of 6mm²
- Particularly suitable for special classes or very high output levels



Current transformers JKS / JKS-S

JKS-S

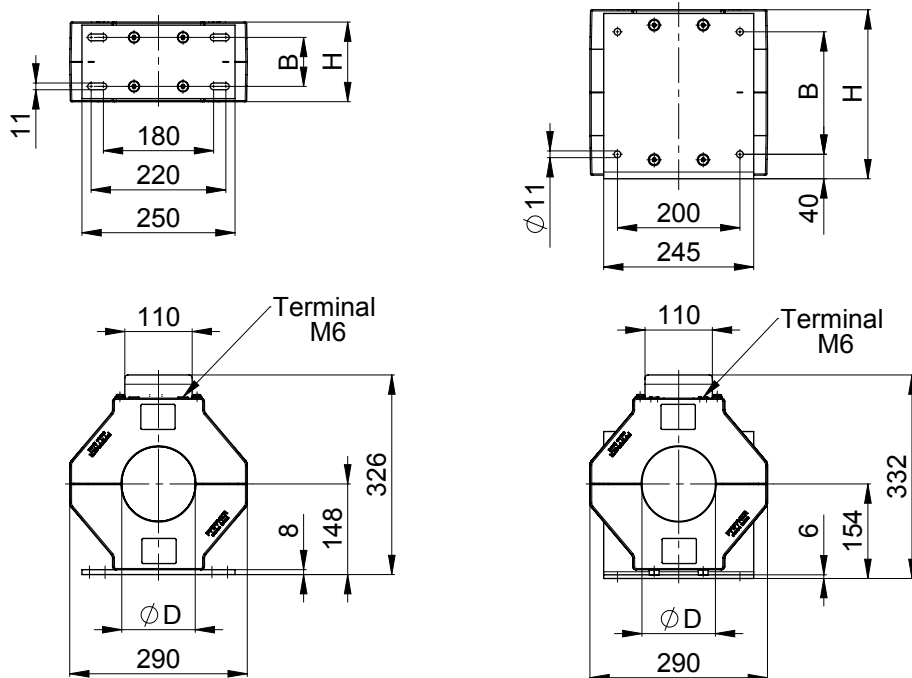

Type JKS / JKS-S

Standard	DIN/IEC/IEEE	
Highest voltage for equipment	kV	0.72
Rated power-frequency withstand voltage	kV	3
Frequency	Hz	16.7/50/60
Primary rated current	A	1-3000
Secondary rated current	A	1/5
Rated short-time thermal current [I _{th}]	kA/1s	100 x I _n
Rated dynamic current [I _{dyn}]	kA	2.5 x I _{th}
Accuracy class	0.1-3; 0.2S; 0.5S; P; PR; PX; PXR; TPX; TPY	
Max. number of cores	1	

Type JKS-S

Height of unit	H	mm	130	200	270
Fastening dimension	B	mm	80	150	200
Diameter	D	mm	90 / 120 / 150	90 / 120 / 150	90 / 120 / 150





Current transformers JKF

Type JKF cable current transformers are used in outdoor switchgears. They transform high currents up to 4000 A into standardised values for meters, measuring and protection devices.

The outdoor version of the cable current transformer is designed for installation on fully insulated medium and high voltage cables or for installation on medium and high voltage bushings. This enables space-saving system design. Primary currents of up to 4000 A can be measured.

A specific core padding and the complete casting of all active parts in cycloaliphatic epoxy resin suitable for outdoor applications ensures that the magnetic properties, and therefore the class accuracy, remain constant for decades.

The standard secondary terminal box permits a housing degree of protection up to IP 65.

Thanks to a wide range of geometric dimensions the cable current transformer can be adapted to customer requirements. Applicable installation options are also available in various designs. Any type of installation position can be realised.

The transformers are designed according to applicable national and international standards. Designs meeting customer-specific standards are generally possible.



Advantages JKF

- Suitable for installation over fully insulated HV and MV cables
- Suitable for installation on bushings
- Suitable for indoor and outdoor applications with degree of protection IP 20, IP 40 or IP 65
- Wide range of geometric dimensions
- Any installation position



Current transformers JKF

Example dimensional picture

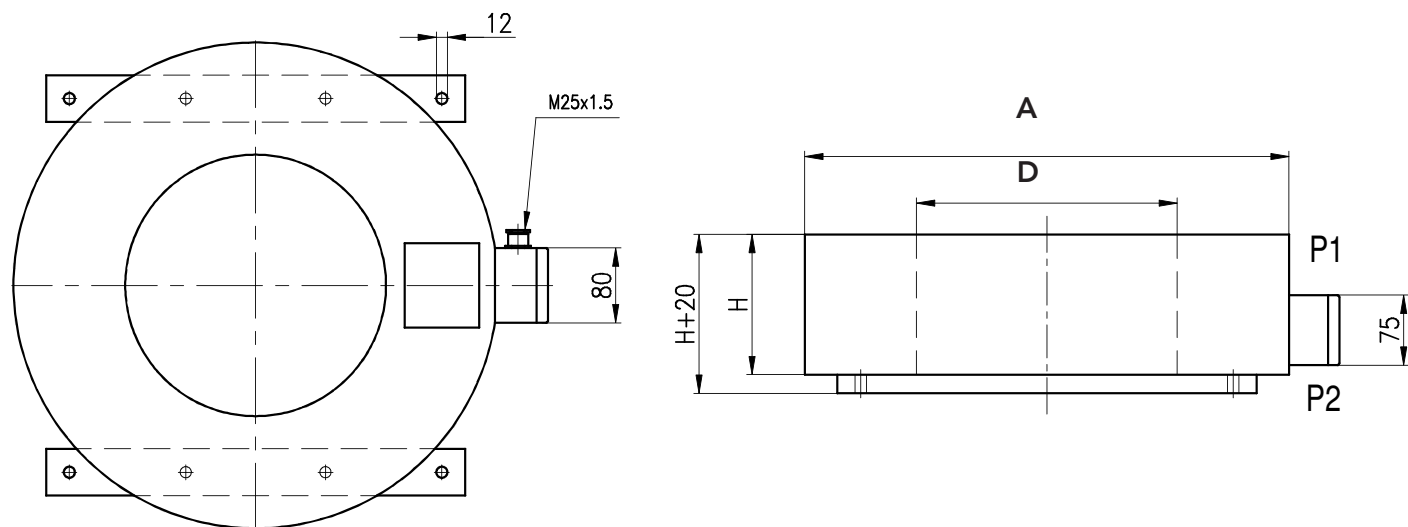

Type JKF		
Standard		DIN/IEC/IEEE
Highest voltage for equipment	kV	0.72
Rated power-frequency withstand voltage	kV	3
Frequency	Hz	16.7/50/60
Primary rated current	A	1–4000
Secondary rated current	A	1/5
Rated short-time thermal current [I _{th}]	kA/1s	100 x I _n
Rated dynamic current [I _{dyn}]	kA	2.5 x I _{th}
Accuracy class		0.1–3; 0.2S; 0.5S; P; PR; PX; PXR; TPX; TPY; TPZ
Max. number of cores		1

Type JKF		
Height of unit	H mm	max. 350
Internal diameter	D mm	160–1200
External diameter	A mm	400–1400

other dimensions on request



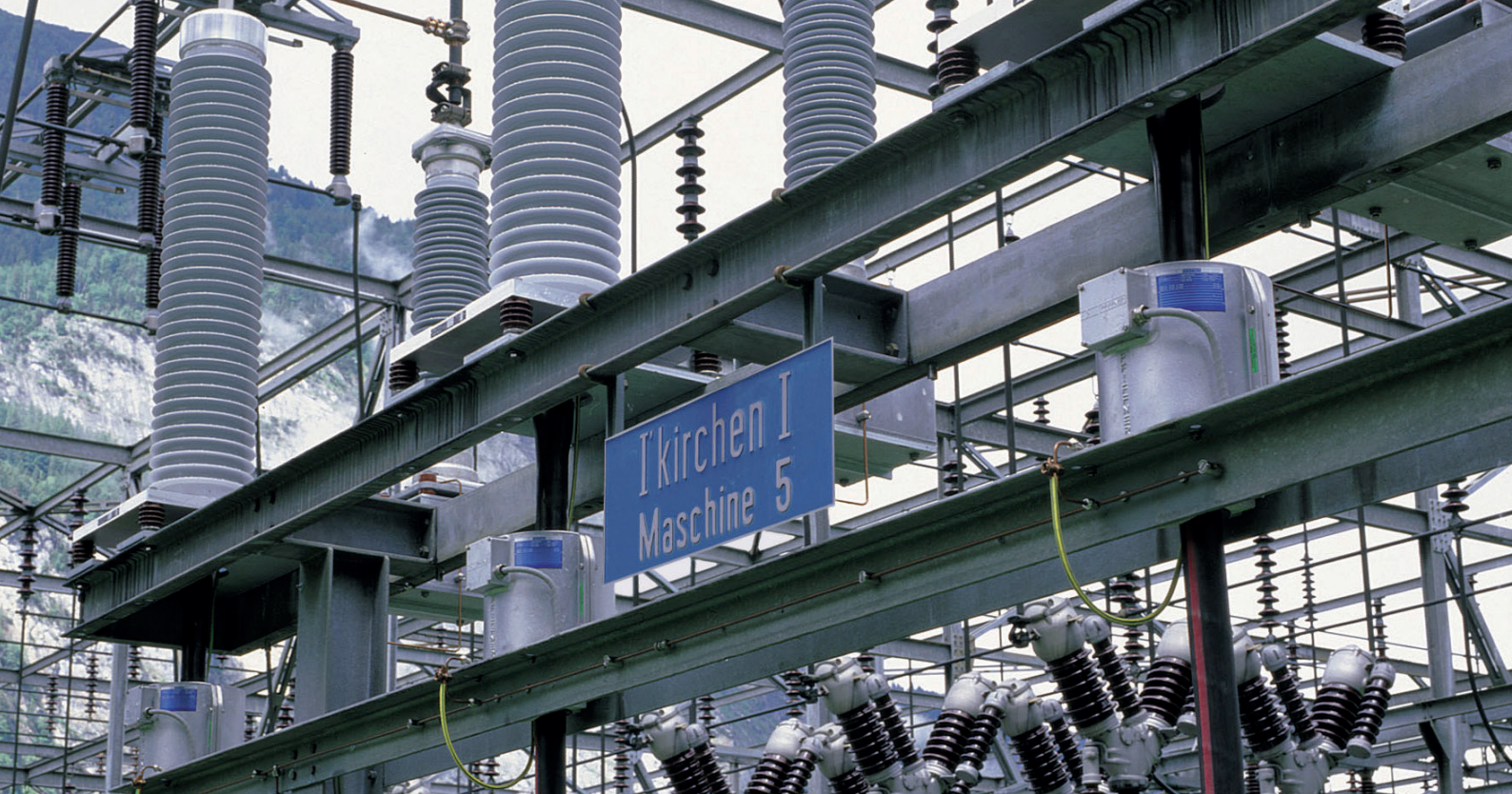

Current transformers JK-G / JKS-G

Cable current transformers of type JK-G/JKS-G are used in outdoor applications for medium or high voltage systems. They are mounted over the high or medium voltage cable and transform currents up to 3000 A into standardised values for meters, measuring and protection tasks.

The cable provides the insulation against high voltage in this transformer type and also represents the primary winding of the current transformer. The current transformer itself is installed on a frame or cross-member over the cable.

The active parts are cast in a polyurethane resin protected by an aluminium housing. The split core current transformers are opened and closed with M8 screws located on the sides.

The secondary terminals are routed in a terminal box to M6 cast sockets. The connection to the secondary circuit can be realised with appropriately sized cable lugs.

Type JK-G

The type JK-G current transformer is a single unit. Up to 4 cores are possible, depending on the type. An IP 65 degree of protection is achieved here. With regards to installation, only vertical mounting with $\pm 60^\circ$ deviation for reasons of outdoor reliability.

Type JKS-G

The type JKS-G current transformer has a split core. Maximum of two cores possible, dependent on the translation and class. An IP 53 degree of protection is achieved here. With regards to installation, only vertical mounting with $\pm 30^\circ$ deviation for reasons of outdoor reliability.

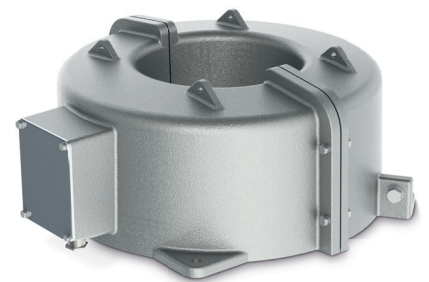

Advantages JK-G (JKS-G)

- Suitable for subsequent installation over the cable in outdoor switchgear
- Degree of protection possible up to IP 65 (IP 53)
- Primary currents possible up to 3000 A
- Suitable for up to 4 (2) current transformer cores, dependent on translation and class
- 4 different transformer hole diameters: 85 mm, 115 mm, 145 mm, 225 mm



Current transformers JK-G / JKS-G

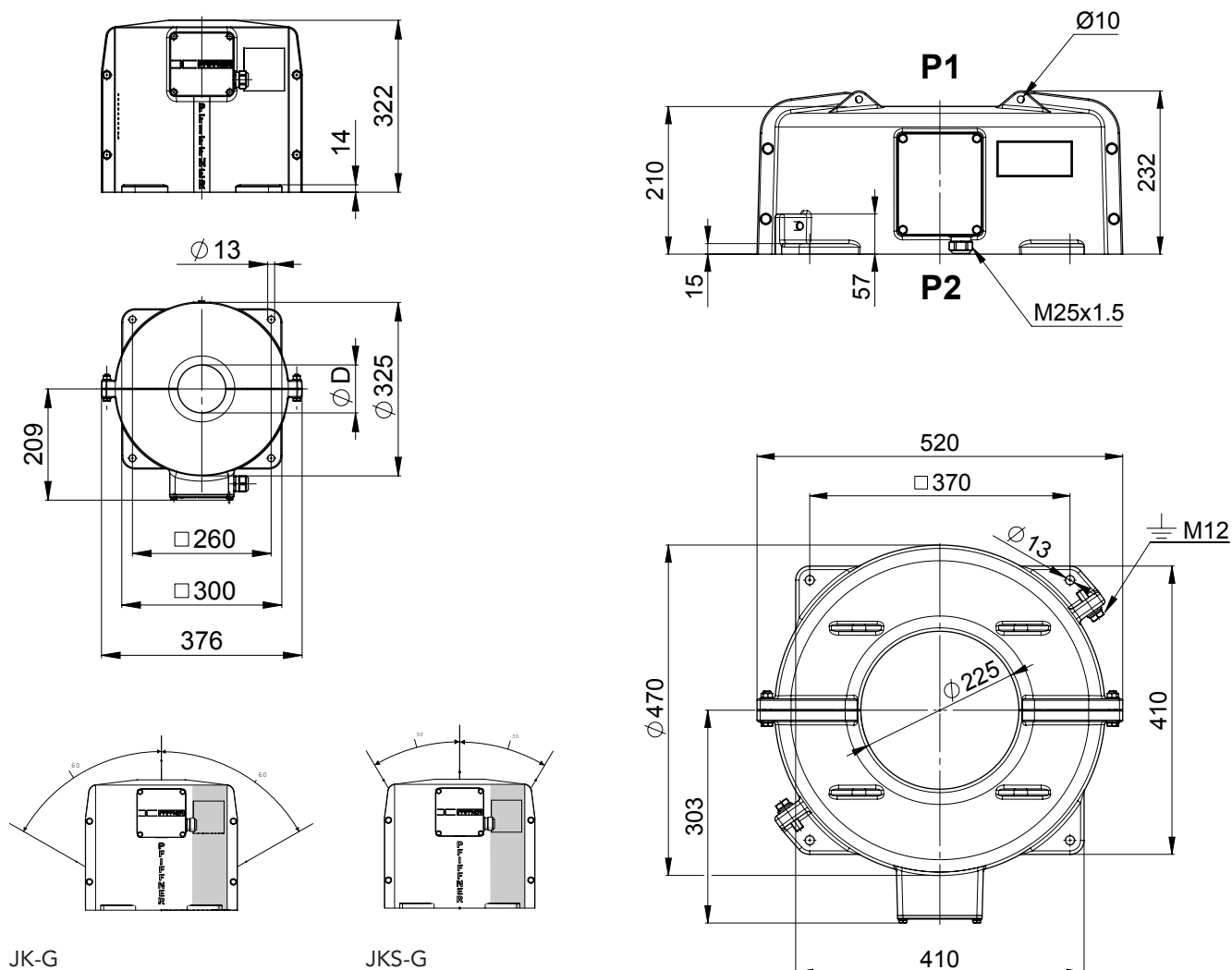

Type JK-G / JKS-G

Standard		DIN/IEC/IEEE
Highest voltage for equipment	kV	0.72
Rated power-frequency withstand voltage	kV	3
Frequency	Hz	16.7 / 50 / 60
Primary rated current	A	1–3000
Secondary rated current	A	1/5
Rated short-time thermal current [I _{th}]	kA/1s	100 x I _n
Rated dynamic current [I _{dyn}]	kA	2.5 x I _{th}
Accuracy class		0.1–3; 0.2S; 0.5S; P; PR; PX; PXR; TPX; TPY

Type	JK-G	JKS-G
Diameter	mm 80 / 110 / 140 / 225	85 / 115 / 145 / 225





Current transformers JLD (12–170) kV

Bar current transformers of type JLD are used in indoor and outdoor applications for medium or high voltage systems. They transform currents up to 5000 A into standardised values for meters, measuring and protection devices.

Bar current transformers are typically used in wall, floor or ceiling openings. They consist mainly of a wall bushing and the coupled current transformer part. The wall bushing provides the insulation against high voltage and also represents the primary winding of the current transformer. Up to 5 cores can be included in the current transformer part. Degrees of protection can optionally be provided between IP 20 and IP 65.

Bar current transformers of type JLD can be designed for outdoor/outdoor, outdoor/indoor and indoor/indoor applications. The corresponding wall bushing and insulation type of the current transformer part must be appropriately selected. A silicone-shielded wall bushing with a current transformer part cast in outdoor-resistant casting resin is used for outdoor applications.

The current transformer parts are cast in polyurethane (PUR) for indoor applications. A special core padding ensures that the magnetic properties are not affected by thermal compression stresses. This allows the class accuracy to remain constant over decades.



Advantages JLD (12–170) kV

- Suitable for installation in wall, floor and ceiling openings
- Suitable for indoor or outdoor applications with degree of protection up to IP 65
- Primary currents possible up to 5000 A
- Low space requirements as installation possible in wall openings
- Up to 5 cores possible
- High short circuit current values possible



Current transformers JLD (12–170) kV

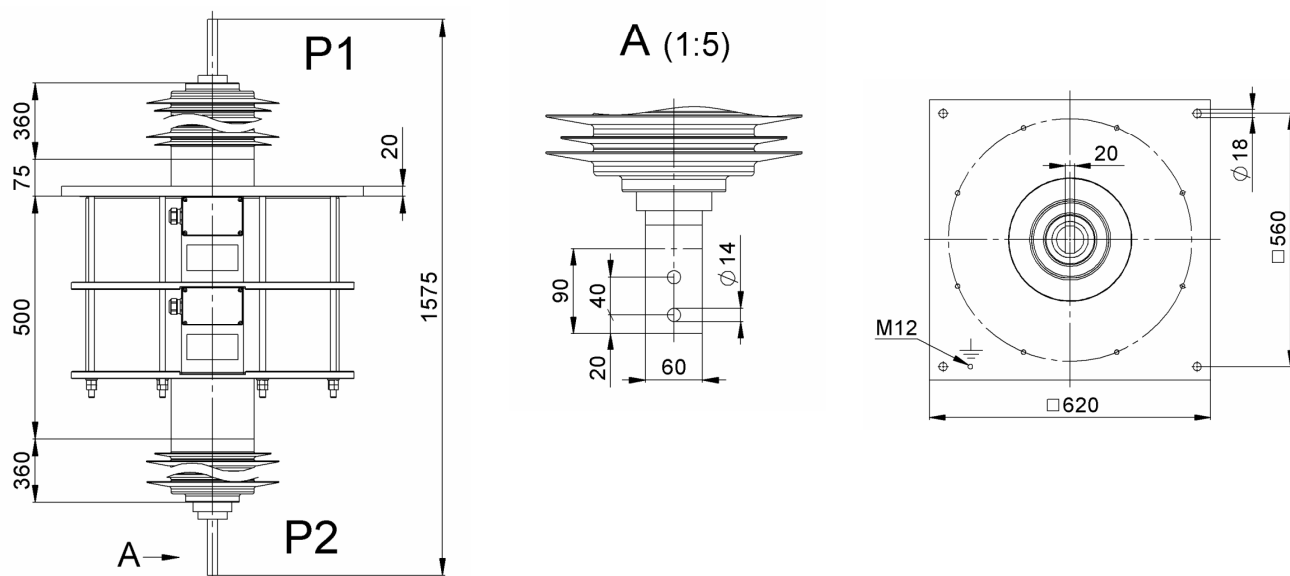

Type JLD		12	24	36	72	123	145	170
Standard		DIN/IEC/IEEE						
Highest voltage for equipment	kV	12	24	36	72.5	123	145	170
Rated power-frequency withstand voltage	kV		50	70	140	230	275	325
Rated lightning impulse withstand voltage	kV		125	170	325	550	650	750
Frequency	Hz	16.7/50/60						
Primary rated current	A	1–5000						
Secondary rated current	A	1/5						
Rated short-time thermal current [I _{th}]	kA/1s	100 x I _n						
Rated dynamic current [I _{dyn}]	kA	2.5 x I _{th}						
Accuracy class		0.1–3; 0.2S; 0.5S; P; PR; PX; PXR; TPX; TPY; TPZ						
Max. number of cores		5						



Global presence

PIFFNER Instrument Transformers Ltd
5042 Hirschthal
Switzerland

☎ +41 (0)62 7392828
✉ sales@pmw.ch
💻 www.pfiffner-group.com/pch

PIFFNER Systems Ltd
4303 Kaiseraugst
Switzerland

☎ +41 (0)61 4676111
✉ info@pfiffner-systems.com
💻 www.pfiffner-systems.com

PIFFNER Deutschland GmbH
25524 Itzehoe
Germany

☎ +49 (0)48 21408270
✉ sales@pfiffner-messwandler.de
💻 www.pfiffner-group.com/pde

PIFFNER Transformatör A.S.
06750 Akyurt/Ankara
Turkey

☎ +90 (0)31 28475521
✉ info@pfiffner.com.tr
💻 www.pfiffner-group.com/ptr

PIFFNER do Brasil Ltda
88307-740 Itajaí
Brazil

☎ +55 (0)47 33481700
✉ pfiffner@pfiffner.com.br
💻 www.pfiffner-group.com/pbr

PIFFNER Instr. Transf. private Ltd
178/2 Village Sarul, Nashik
India

☎ +91 62 9823010690
✉ info@pfiffner.in
💻 www.pfiffner-group.com/in

MGC Moser-Glaser Ltd
4303 Kaiseraugst
Switzerland

☎ +41 (0)61 4676111
✉ info@mgc.ch
💻 www.mgc.ch

ALPHA Elektrotechnik Ltd
2560 Nidau
Switzerland

☎ +41 (0)32 3328700
✉ mail@alpha-et.ch
💻 www.alpha-et.ch

HAEFELY Ltd
4052 Basel
Switzerland

☎ +41 (0)61 373 41 11
✉ sales@haefely.com
💻 www.haefely.com

This document has been drawn up with the utmost care. We cannot, however, guarantee that it is entirely complete, correct or up-to-date.
©Copyright PFIFFNER / Subject to change without notice 2020.04

